

INSTRUCTION MANUAL

# Router

## M3600

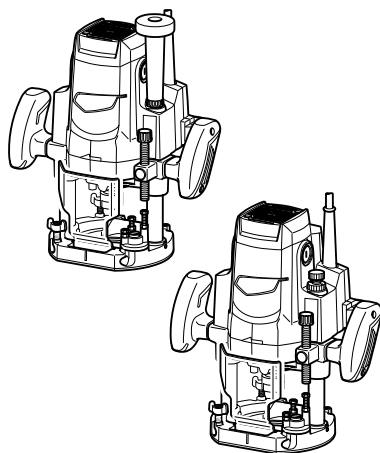

DOUBLE INSULATION



Read before use.

# SPECIFICATIONS

<b>Model:</b>	<b>M3600</b>
Collet chuck capacity	12 mm or 1/2"
Plunge capacity	0 - 60 mm
No load speed	22,000 min <sup>-1</sup>
Overall height	300 mm
Net weight	5.5 kg
Safety class	□/II

- Due to our continuing program of research and development, the specifications herein are subject to change without notice.
- Specifications may differ from country to country.
- Weight according to EPTA-Procedure 01/2003

## Symbols

The following show the symbols used for the equipment. Be sure that you understand their meaning before use.



Read instruction manual.



DOUBLE INSULATION



Only for EU countries  
Do not dispose of electric equipment together with household waste material! In observance of the European Directive, on Waste Electric and Electronic Equipment and its implementation in accordance with national law, electric equipment that have reached the end of their life must be collected separately and returned to an environmentally compatible recycling facility.

## Intended use

The tool is intended for flush trimming and profiling of wood, plastic and similar materials.

## Power supply

The tool should be connected only to a power supply of the same voltage as indicated on the nameplate, and can only be operated on single-phase AC supply. They are double-insulated and can, therefore, also be used from sockets without earth wire.

## For public low-voltage distribution systems of between 220 V and 250 V.

Switching operations of electric apparatus cause voltage fluctuations. The operation of this device under unfavorable mains conditions can have adverse effects to the operation of other equipment. With a mains impedance equal or less than 0.35 Ohms it can be presumed that there will be no negative effects. The mains socket used for this device must be protected with a fuse or protective circuit breaker having slow tripping characteristics.

## Noise

The typical A-weighted noise level determined according to EN60745:

Sound pressure level ( $L_{pA}$ ) : 86 dB(A)

Sound power level ( $L_{WA}$ ) : 97 dB (A)

Uncertainty (K) : 3 dB(A)

**⚠WARNING:** Wear ear protection.

## Vibration

The vibration total value (tri-axial vector sum) determined according to EN60745:

Work mode: cutting grooves in MDF

Vibration emission ( $a_h$ ) : 2.5 m/s<sup>2</sup>

Uncertainty (K) : 1.5 m/s<sup>2</sup>

**NOTE:** The declared vibration emission value has been measured in accordance with the standard test method and may be used for comparing one tool with another.

**NOTE:** The declared vibration emission value may also be used in a preliminary assessment of exposure.

**⚠WARNING:** The vibration emission during actual use of the power tool can differ from the declared emission value depending on the ways in which the tool is used.

**⚠WARNING:** Be sure to identify safety measures to protect the operator that are based on an estimation of exposure in the actual conditions of use (taking account of all parts of the operating cycle such as the times when the tool is switched off and when it is running idle in addition to the trigger time).

## EC Declaration of Conformity

**For European countries only**

Makita declares that the following Machine(s):

Designation of Machine: Router

Model No./ Type: M3600

Conforms to the following European Directives: 2006/42/EC

They are manufactured in accordance with the following standard or standardized documents: EN60745

The technical file in accordance with 2006/42/EC is available from:  
Makita, Jan-Baptist Vinkstraat 2, 3070, Belgium  
4.8.2015



Yasushi Fukaya  
Director  
Makita, Jan-Baptist Vinkstraat 2, 3070, Belgium

## General power tool safety warnings

**▲WARNING:** Read all safety warnings and all instructions. Failure to follow the warnings and instructions may result in electric shock, fire and/or serious injury.

## Save all warnings and instructions for future reference.

The term "power tool" in the warnings refers to your mains-operated (corded) power tool or battery-operated (cordless) power tool.

### Work area safety

1. **Keep work area clean and well lit.** Cluttered or dark areas invite accidents.
2. **Do not operate power tools in explosive atmospheres, such as in the presence of flammable liquids, gases or dust.** Power tools create sparks which may ignite the dust or fumes.
3. **Keep children and bystanders away while operating a power tool.** Distractions can cause you to lose control.

### Electrical Safety

1. **Power tool plugs must match the outlet. Never modify the plug in any way. Do not use any adapter plugs with earthed (grounded) power tools.** Unmodified plugs and matching outlets will reduce risk of electric shock.
2. **Avoid body contact with earthed or grounded surfaces such as pipes, radiators, ranges and refrigerators.** There is an increased risk of electric shock if your body is earthed or grounded.
3. **Do not expose power tools to rain or wet conditions.** Water entering a power tool will increase the risk of electric shock.
4. **Do not abuse the cord. Never use the cord for carrying, pulling or unplugging the power tool. Keep cord away from heat, oil, sharp edges or moving parts.** Damaged or entangled cords increase the risk of electric shock.
5. **When operating a power tool outdoors, use an extension cord suitable for outdoor use.** Use of a cord suitable for outdoor use reduces the risk of electric shock.
6. **If operating a power tool in a damp location is unavoidable, use a residual current device (RCD) protected supply.** Use of an RCD reduces the risk of electric shock.
7. **Use of power supply via an RCD with a rated residual current of 30 mA or less is always recommended.**

### Personal Safety

1. **Stay alert, watch what you are doing and use common sense when operating a power tool. Do not use a power tool while you are tired or under the influence of drugs, alcohol or medication.** A moment of inattention while operating power tools may result in serious personal injury.
2. **Use personal protective equipment. Always wear eye protection.** Protective equipment such as dust mask, non-skid safety shoes, hard hat, or hearing protection used for appropriate conditions will reduce personal injuries.
3. **Prevent unintentional starting. Ensure the switch is in the off-position before connecting to power source and/or battery pack, picking up or carrying the tool.** Carrying power tools with your finger on the switch or energising power tools that have the switch on invites accidents.
4. **Remove any adjusting key or wrench before turning the power tool on.** A wrench or a key left attached to a rotating part of the power tool may result in personal injury.
5. **Do not overreach. Keep proper footing and balance at all times.** This enables better control of the power tool in unexpected situations.
6. **Dress properly. Do not wear loose clothing or jewellery. Keep your hair, clothing, and gloves away from moving parts.** Loose clothes, jewellery or long hair can be caught in moving parts.
7. **If devices are provided for the connection of dust extraction and collection facilities, ensure these are connected and properly used.** Use of dust collection can reduce dust-related hazards.

### Power tool use and care

1. **Do not force the power tool. Use the correct power tool for your application.** The correct power tool will do the job better and safer at the rate for which it was designed.
2. **Do not use the power tool if the switch does not turn it on and off.** Any power tool that cannot be controlled with the switch is dangerous and must be repaired.
3. **Disconnect the plug from the power source and/or the battery pack from the power tool before making any adjustments, changing accessories, or storing power tools.** Such preventive safety measures reduce the risk of starting the power tool accidentally.
4. **Store idle power tools out of the reach of children and do not allow persons unfamiliar with the power tool or these instructions to operate the power tool.** Power tools are dangerous in the hands of untrained users.
5. **Maintain power tools. Check for misalignment or binding of moving parts, breakage of parts and any other condition that may affect the power tool's operation.** If damaged, have the power tool repaired before use. Many accidents are caused by poorly maintained power tools.
6. **Keep cutting tools sharp and clean.** Properly maintained cutting tools with sharp cutting edges are less likely to bind and are easier to control.
7. **Use the power tool, accessories and tool bits etc. in accordance with these instructions, taking into account the working conditions and the work to be performed.** Use of the power tool for operations different from those intended could result in a hazardous situation.

## Service

1. Have your power tool serviced by a qualified repair person using only identical replacement parts. This will ensure that the safety of the power tool is maintained.
2. Follow instruction for lubricating and changing accessories.
3. Keep handles dry, clean and free from oil and grease.

## Router safety warnings

1. Hold power tool by insulated gripping surfaces, because the cutter may contact its own cord. Cutting a "live" wire may make exposed metal parts of the power tool "live" and shock the operator.
2. Use clamps or another practical way to secure and support the workpiece to a stable platform. Holding the work by your hand or against the body leaves it unstable and may lead to loss of control.
3. Wear hearing protection during extended period of operation.
4. Handle the router bits very carefully.
5. Check the router bit carefully for cracks or damage before operation. Replace cracked or damaged bit immediately.
6. Avoid cutting nails. Inspect for and remove all nails from the workpiece before operation.
7. Hold the tool firmly with both hands.
8. Keep hands away from rotating parts.
9. Make sure the router bit is not contacting the workpiece before the switch is turned on.
10. Before using the tool on an actual workpiece, let it run for a while. Watch for vibration or wobbling that could indicate improperly installed bit.
11. Be careful of the router bit rotating direction and the feed direction.
12. Do not leave the tool running. Operate the tool only when hand-held.
13. Always switch off and wait for the router bit to come to a complete stop before removing the tool from workpiece.
14. Do not touch the router bit immediately after operation; it may be extremely hot and could burn your skin.
15. Do not smear the tool base carelessly with thinner, gasoline, oil or the like. They may cause cracks in the tool base.
16. Use router bits of the correct shank diameter suitable for the speed of the tool.
17. Some material contains chemicals which may be toxic. Take caution to prevent dust inhalation and skin contact. Follow material supplier safety data.
18. Always use the correct dust mask/respirator for the material and application you are working with.

## SAVE THESE INSTRUCTIONS.

**⚠WARNING:** DO NOT let comfort or familiarity with product (gained from repeated use) replace strict adherence to safety rules for the subject product. MISUSE or failure to follow the safety rules stated in this instruction manual may cause serious personal injury.

## FUNCTIONAL DESCRIPTION

**⚠CAUTION:** Always be sure that the tool is switched off and unplugged before adjusting or checking function on the tool.

### Adjusting the depth of cut

Place the tool on a flat surface. Loosen the lock lever and lower the tool body until the router bit just touches the flat surface. Press the lock lever down to lock the tool body. While pressing the fast-feed button, move the stopper pole up or down until the desired depth of cut is obtained. Minute depth adjustments can be obtained by turning the stopper pole (1.5 mm (1/16") per turn).

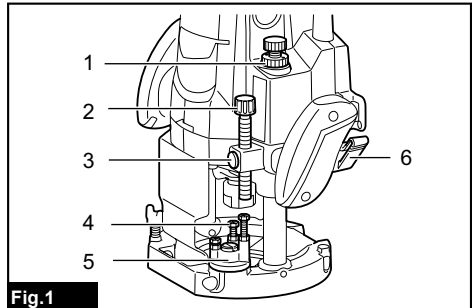

Fig.1

- 1. Nylon nut 2. Stopper pole 3. Fast-feed button  
4. Adjusting hex bolt 5. Stopper 6. Lock lever

**⚠CAUTION:** The depth of cut should not be more than 20 mm (13/16") at a pass when cutting grooves. For extra-deep grooving operations, make two or three passes with progressively deeper router bit settings.

### Nylon nut

#### For tool without the knob

The upper limit of the tool body can be adjusted by turning the nylon nut. Do not lower the nylon nut too low. The router bit will protrude dangerously.

#### For tool with the knob

By turning the knob, the upper limit of the tool body can be adjusted. When the tip of the router bit is retracted more than required in relation to the base plate surface, turn the knob to lower the upper limit. Do not lower the knob too low. The router bit will protrude dangerously.

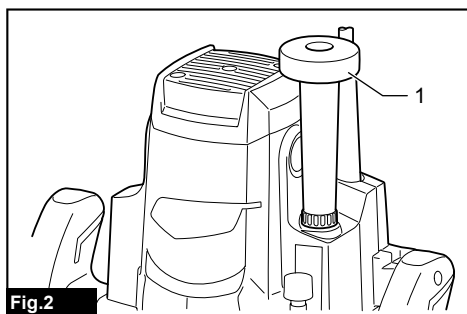

Fig.2

► 1. Knob

**CAUTION:** Since excessive cutting may cause overload of the motor or difficulty in controlling the tool, the depth of cut should not be more than 20 mm (13/16") at a pass when cutting grooves. When you wish to cut grooves more than 20 mm (13/16") deep, make several passes with progressively deeper router bit settings.

**CAUTION:** Do not lower the knob too low. The router bit will protrude dangerously.

## Stopper block

As the rotary stopper has three adjusting hex bolts, you can easily obtain three different depths of cut without readjusting the stopper pole. To adjust the hex bolts, loosen the hex nuts on them and turn the hex bolts. After obtaining the desired position, tighten the hex nuts to secure the hex bolts.

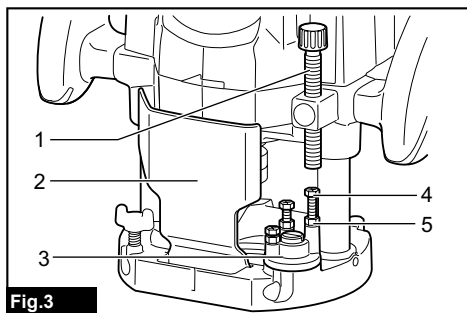

Fig.3

► 1. Stopper pole 2. Chip deflector 3. Stopper  
4. Adjusting hex bolt 5. Hex nut

## Switch action

**CAUTION:** Before plugging in the tool, always check to see that the tool is switched off.

**CAUTION:** Make sure that the shaft lock is released before the switch is turned on.

To start the tool, move the switch lever to the I position. To stop the tool, move the switch lever to the O position.

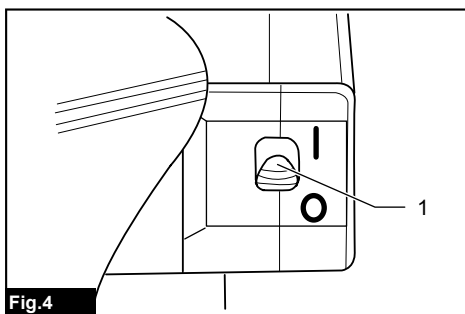

Fig.4

► 1. Switch lever

**CAUTION:** Hold the tool firmly when turning off the tool, to overcome the reaction.

## ASSEMBLY

**CAUTION:** Always be sure that the tool is switched off and unplugged before carrying out any work on the tool.

## Installing or removing the router bit

Insert the router bit all the way into the collet cone. Press the shaft lock to keep the shaft stationary and use the wrench to tighten the collet nut securely. When using router bits with smaller shank diameter, first insert the appropriate collet sleeve into the collet cone, then install the router bit as illustrated. To remove the router bit, follow the installation procedure in reverse.

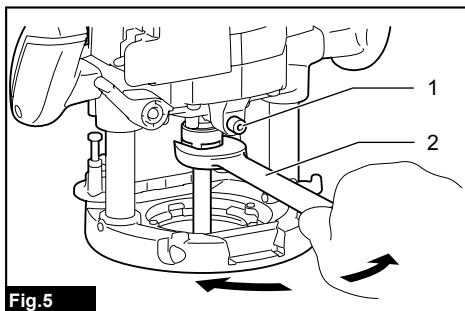

Fig.5

► 1. Shaft lock 2. Wrench

**CAUTION:** Install the router bit securely. Always use only the wrench provided with the tool. A loose or overtightened router bit can be dangerous.

**CAUTION:** Do not tighten the collet nut without inserting a router bit or install small shank bits without using a collet sleeve. Either can lead to breakage of the collet cone.

# OPERATION

**⚠ CAUTION:** Before operation, always make sure that the tool body automatically rises to the upper limit and the router bit does not protrude from the tool base when the lock lever is loosened.

**⚠ CAUTION:** Before operation, always make sure that the chip deflector is installed properly.

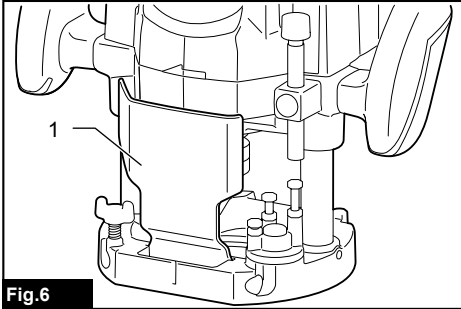

Fig. 6

► 1. Chip deflector

Set the tool base on the workpiece to be cut without the router bit making any contact. Then turn the tool on and wait until the router bit attains full speed. Lower the tool body and move the tool forward over the workpiece surface, keeping the tool base flush and advancing smoothly until the cutting is complete.

When doing edge cutting, the workpiece surface should be on the left side of the router bit in the feed direction.

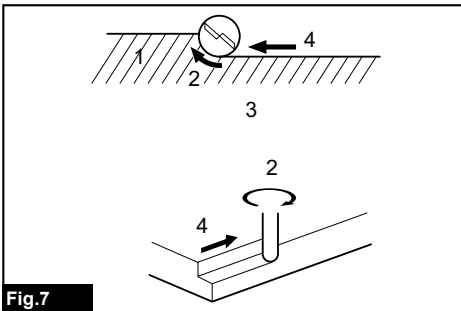

Fig. 7

► 1. Workpiece 2. Bit revolving direction 3. View from the top of the tool 4. Feed direction

**NOTE:** Moving the tool forward too fast may cause a poor quality of cut, or damage to the router bit or motor. Moving the tool forward too slowly may burn and mar the cut. The proper feed rate will depend on the router bit size, the kind of workpiece and depth of cut.

Before beginning the cut on the actual workpiece, it is advisable to make a sample cut on a piece of scrap lumber. This will show exactly how the cut will look as well as enable you to check dimensions.

**NOTE:** When using the straight guide or the trimmer guide, be sure to install it on the right side in the feed direction. This will help to keep it flush with the side of the workpiece.

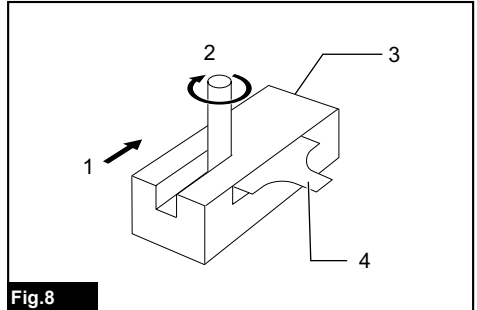

Fig. 8

► 1. Feed direction 2. Router bit revolving direction 3. Workpiece 4. Straight guide

## Straight guide

The straight guide is effectively used for straight cuts when chamfering or grooving.

### Straight guide (Type A)

#### Optional accessory

Install the straight guide on the guide holder with the thumb screw (B). Insert the guide holder into the holes in the tool base and tighten the thumb screw (A). To adjust the distance between the router bit and the straight guide, loosen the thumb screw (B) and turn the fine adjusting screw. At the desired distance, tighten the thumb screw (B) to secure the straight guide in place.

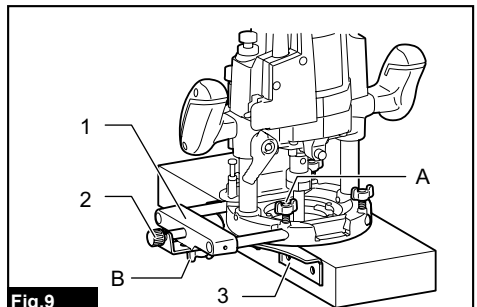

Fig. 9

► 1. Guide holder 2. Fine adjusting screw 3. Straight guide

## Straight guide (Type B)

### Optional accessory

Insert the straight guide into the holes in the tool base and tighten the thumb screw. To adjust the distance between the router bit and the straight guide, loosen the thumb screw. At the desired distance, tighten the thumb screw to secure the straight guide in place.

Wider straight guide of desired dimensions may be made by using the convenient holes in the guide to bolt on extra pieces of wood.

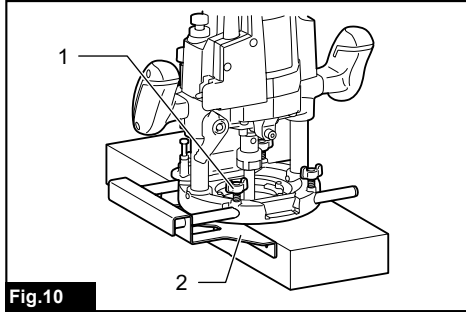

Fig.10

- 1. Thumb screw 2. Straight guide

When using a large diameter router bit, attach pieces of wood to the straight guide which have a thickness of more than 15 mm (5/8") to prevent the router bit from striking the straight guide.

When cutting, move the tool with the straight guide flush with the side of the workpiece.

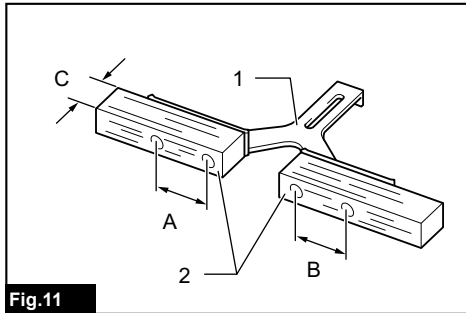

Fig.11

- 1. Straight guide 2. Wood

A=55 mm (2-3/16")

B=55 mm (2-3/16")

C=15 mm (5/8") or thicker

### Templet guide

The templet guide provides a sleeve through which the router bit passes, allowing use of the tool with templet patterns. To install the templet guide, loosen the screws on the tool base, insert the templet guide and then tighten the screws.

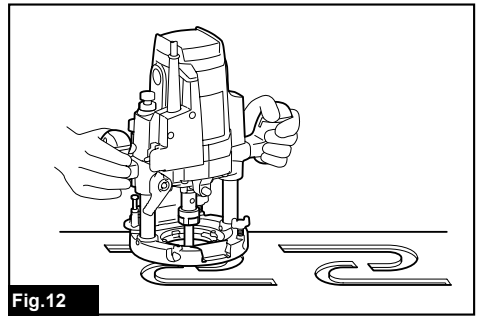

Fig.12

Secure the templet to the workpiece. Place the tool on the templet and move the tool with the templet guide sliding along the side of the templet.

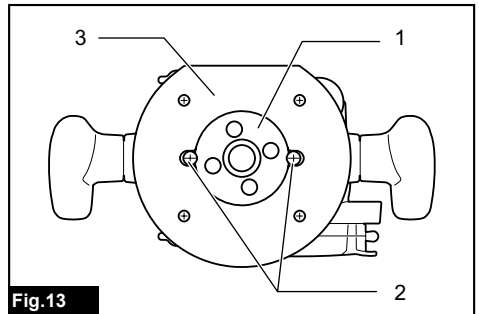

Fig.13

- 1. Templet guide 2. Screws 3. Base plate

**NOTE:** The workpiece will be cut a slightly different size from the templet. Allow for the distance (X) between the router bit and the outside of the templet guide. The distance (X) can be calculated by using the following equation:

$$\text{Distance (X)} = (\text{outside diameter of the templet guide} - \text{router bit diameter}) / 2$$

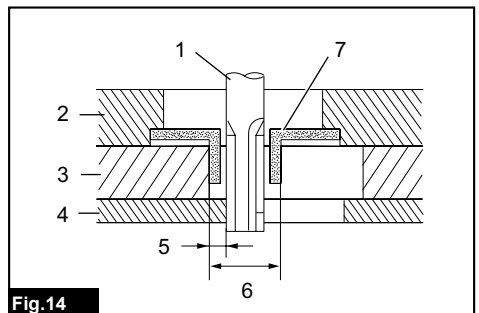

Fig.14

- 1. Router bit 2. Base 3. Templet 4. Workpiece  
5. Distance (X) 6. Outside diameter of the templet guide 7. Templet guide

### Trimmer guide

Trimming, curved cuts in veneers for furniture and the like can be done easily with the trimmer guide. The guide roller rides the curve and assures a fine cut.

## Trimmer guide (Type A)

### Optional accessory

Install the trimmer guide on the guide holder with the thumb screw (B). Insert the guide holder into the holes in the tool base and tighten the thumb screw (A). To adjust the distance between the router bit and the trimmer guide, loosen the thumb screw (B) and turn the fine adjusting screw. When adjusting the guide roller up or down, loosen the thumb screw (C). After adjusting, tighten all the thumb screws securely.

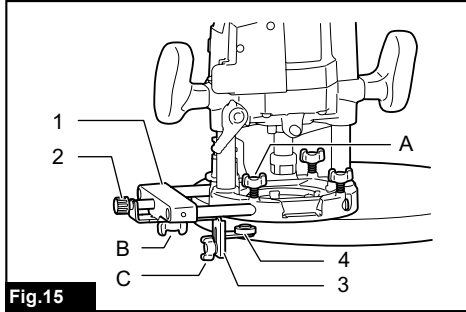

Fig.15

- 1. Guide holder 2. Fine adjusting screw 3. Trimmer guide 4. Guide roller

## Trimmer guide (Type B)

### Optional accessory

Install the trimmer guide on the straight guide with the thumb screws (B). Insert the straight guide into the holes in the tool base and tighten the thumb screw (A). To adjust the distance between the router bit and the trimmer guide, loosen the thumb screws (B). When adjusting the guide roller up or down, loosen the thumb screw (C). After adjusting, tighten all the thumb screws securely.

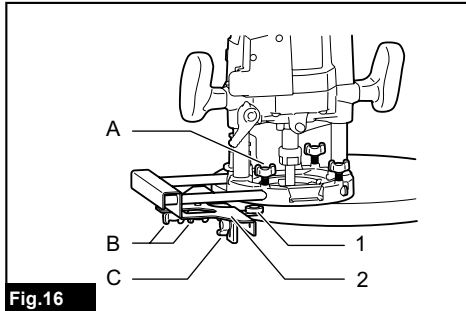

Fig.16

- 1. Guide roller 2. Trimmer guide

When cutting, move the tool with the guide roller riding the side of the workpiece.

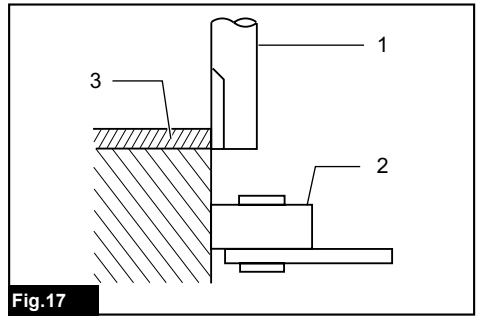

Fig.17

- 1. Router bit 2. Guide roller 3. Workpiece

## Dust cover (For tool with the knob)

### Optional accessory

Dust cover prevents sawdust from being drawn into the tool in the inverted position.

Install the dust cover as illustrated when using the tool with a router stand available in the market. Remove it when using the tool in the normal position.

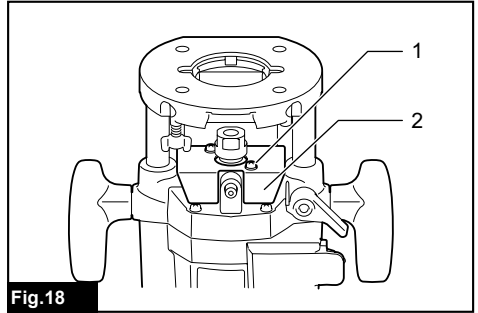

Fig.18

- 1. Screw 2. Dust cover

## Spacer (For tool with the knob)

### Optional accessory

The spacer prevents the router bit from dropping into the chuck when replacing the router bit in the inverted position.

Insert the spacer as illustrated when using the tool with a router stand available in the market.

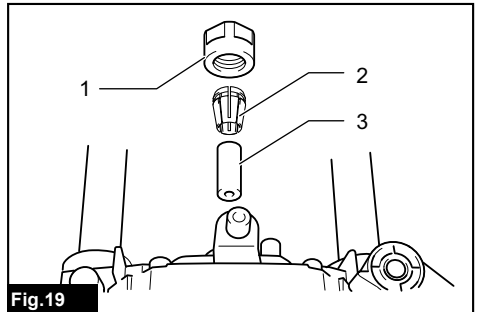

Fig.19

- 1. Collet nut 2. Collet cone 3. Spacer

## Dust extraction

### Optional accessory

Use the vacuum head for dust extraction.

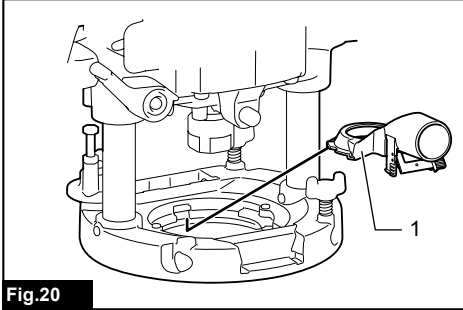

Fig.20

► 1. Vacuum head

### Installing the vacuum head

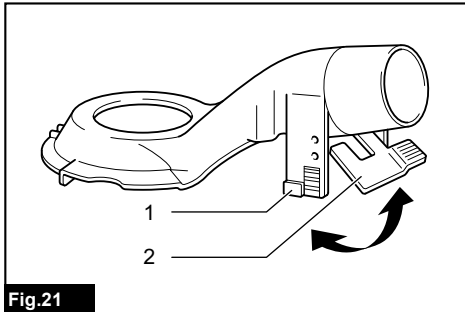

Fig.21

► 1. Support 2. Lock lever

1. Raise the lock lever of the vacuum head.
2. Place the vacuum head on the tool base so that its top will be caught in the hook on the tool base.
3. Insert the supports on the vacuum head into the hooks on the front of the tool base.
4. Push down the lock lever onto the tool base.
5. Connect a vacuum cleaner to the vacuum head.

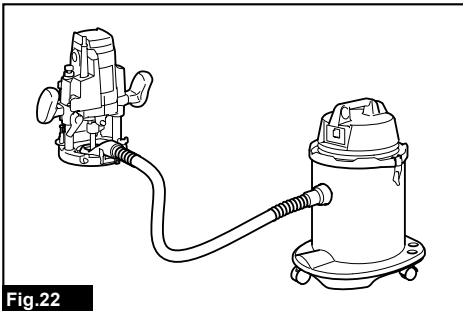

Fig.22

## Removing the vacuum head

1. Raise the lock lever.
2. Pull the vacuum head out of the tool base while holding the supports between thumb and finger.

## MAINTENANCE

**CAUTION:** Always be sure that the tool is switched off and unplugged before attempting to perform inspection or maintenance.

**NOTICE:** Never use gasoline, benzine, thinner, alcohol or the like. Discoloration, deformation or cracks may result.

## Replacing carbon brushes

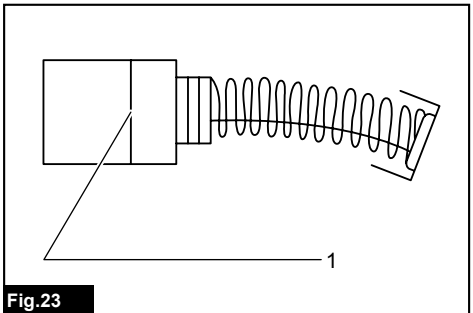

Fig.23

► 1. Limit mark

Check the carbon brushes regularly. Replace them when they wear down to the limit mark. Keep the carbon brushes clean and free to slip in the holders. Both carbon brushes should be replaced at the same time. Use only identical carbon brushes.

1. Use a screwdriver to remove the brush holder caps.
2. Take out the worn carbon brushes, insert the new ones and secure the brush holder caps.

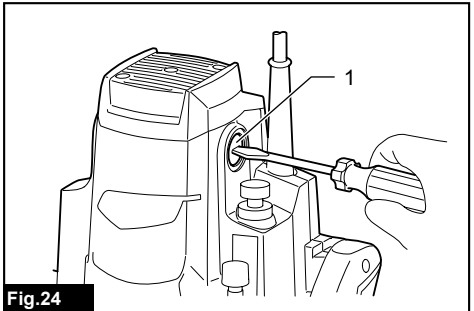

Fig.24

► 1. Brush holder cap

## For tool with the knob

**CAUTION:** Be sure to re-install the knob after inserting new carbon brush.

Release the lock lever and remove the knob by turning it counterclockwise.

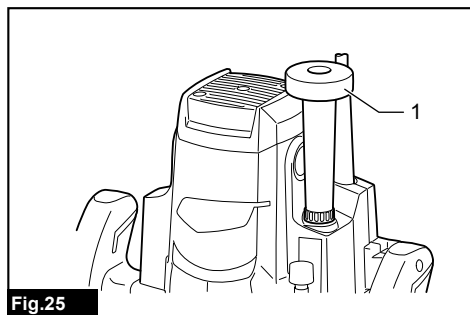

Fig.25

► 1. Knob

**NOTE:** The compression spring will come out of the knob, so be careful not to lose the compression spring.

To maintain product SAFETY and RELIABILITY, repairs, any other maintenance or adjustment should be performed by Makita Authorized or Factory Service Centers, always using Makita replacement parts.

## OPTIONAL ACCESSORIES

### Router bits

#### Straight bit

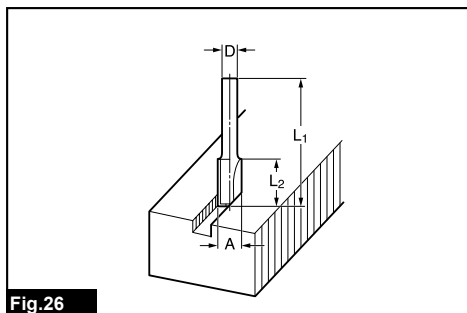

Fig.26

Unit:mm

D	A	L1	L2
6	20	50	15
1/4"			
12	12	60	30
1/2"			
12	10	60	25
1/2"			
8	8	60	25
6	8	50	18
1/4"			
6	6	50	18
1/4"			

#### “U”Grooving bit

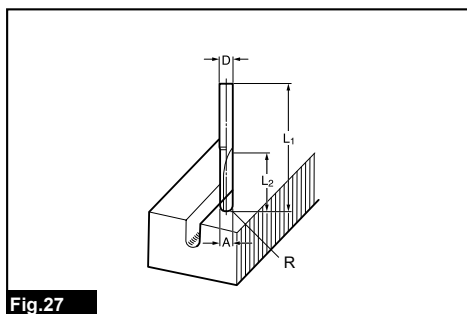

Fig.27

Unit:mm

D	A	L1	L2	R
6	6	50	18	3

## "V" Grooving bit

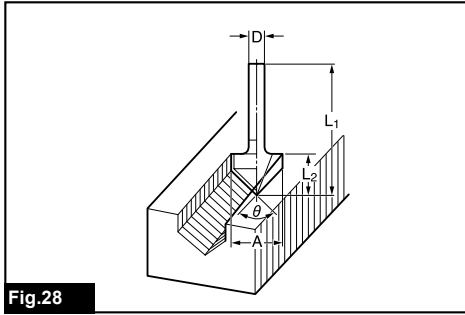

Fig.28

Unit:mm

D	A	L1	L2	θ
1/4"	20	50	15	90°

## Dovetail bit

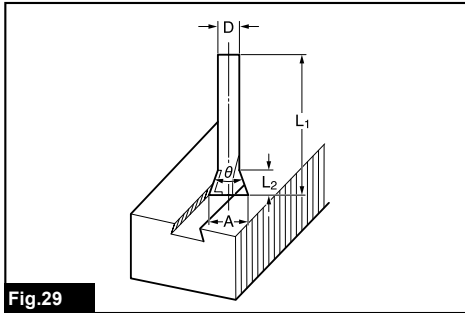

Fig.29

Unit:mm

D	A	L1	L2	θ
8	14.5	55	10	35°
3/8"				
8	14.5	55	14.5	23°
3/8"				
8	12	50	9	30°
3/8"				

## Drill point flush trimming bit

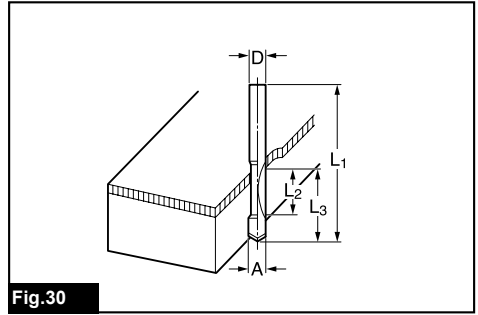

Fig.30

Unit:mm

D	A	L1	L2	L3
12	12	60	20	35
8	8	60	20	35
6	6	60	18	28

## Drill point double flush trimming bit

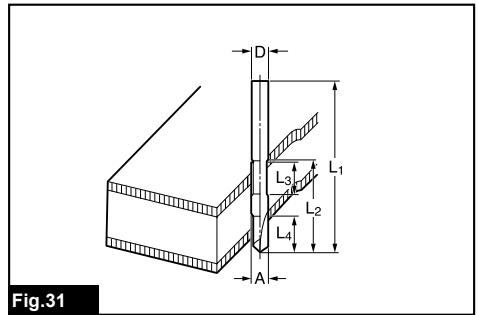

Fig.31

Unit:mm

D	A	L1	L2	L3	L4
6	6	70	40	12	14

## Slotting cutter

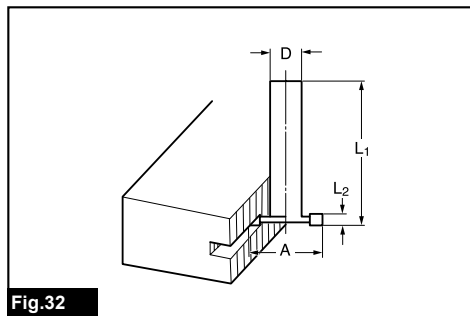

Fig.32

Unit:mm

D	A	L1	L2
12	30	55	6
1/2"			
12	30	55	3
1/2"			

## Board-jointing bit

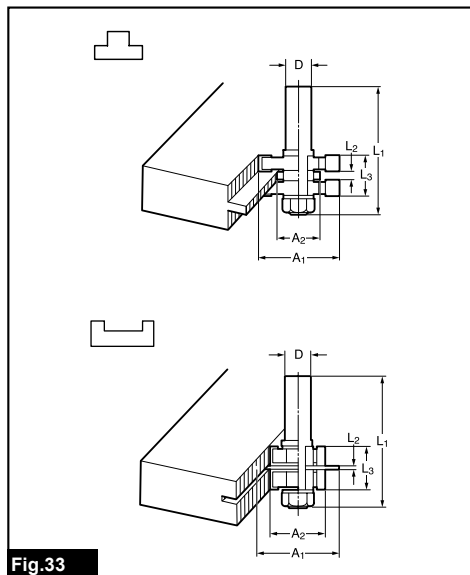

Fig.33

Unit:mm

D	A1	A2	L1	L2	L3
12	38	27	61	4	20

## Corner rounding bit

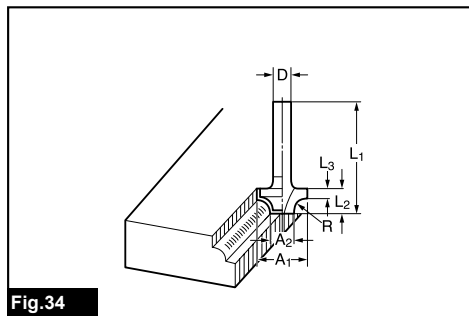

Fig.34

Unit:mm

D	A1	A2	L1	L2	L3	R
6	25	9	48	13	5	8
6	20	8	45	10	4	4

## Chamfering bit

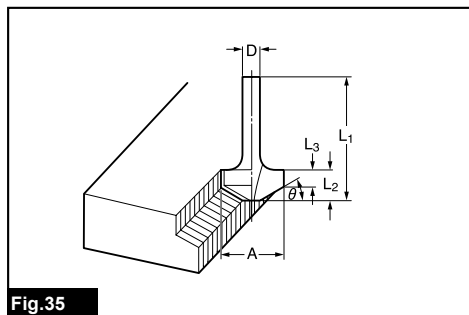
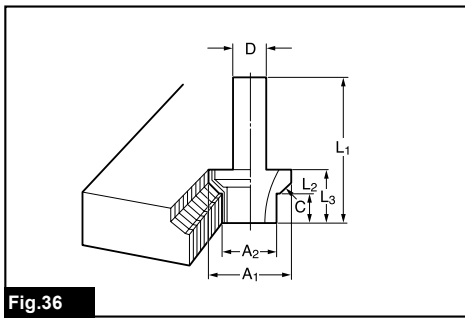

Fig.35

Unit:mm

D	A1	A2	L1	L2	L3	C
12	30	20	55	12	20	4
1/2"						

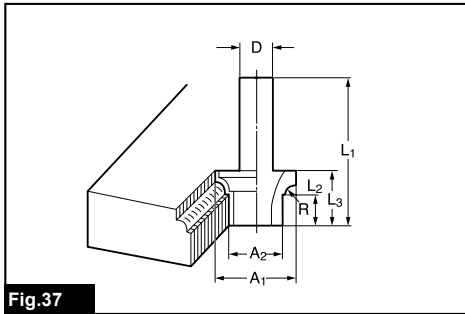

**Fig.36**

Unit:mm

D	A	L1	L2	L3	θ
6	23	46	11	6	30°
6	20	50	13	5	45°
6	20	49	14	2	60°

### Beading bit

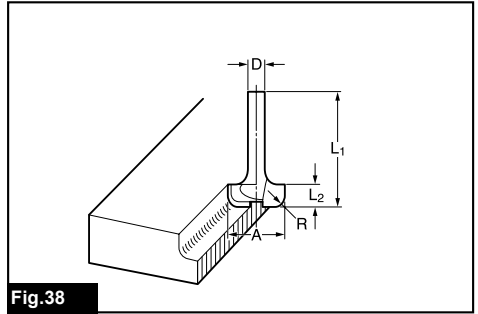

**Fig.37**

Unit:mm

D	A1	A2	L1	L2	L3	R
12	30	20	55	12	20	4
1/2"						

### Cove beading bit

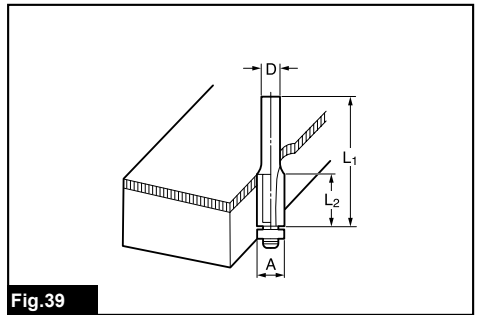

**Fig.38**

Unit:mm

D	A	L1	L2	R
6	20	43	8	4
6	25	48	13	8

### Ball bearing flush trimming bit



**Fig.39**

Unit:mm

D	A	L1	L2
6	10	50	20
1/4"			

### Ball bearing corner rounding bit

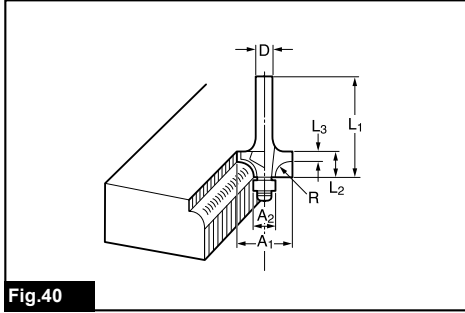

Fig.40

Unit:mm

D	A1	A2	L1	L2	L3	R
6	15	8	37	7	3.5	3
6	21	8	40	10	3.5	6
1/4"	21	8	40	10	3.5	6

### Ball bearing chamfering bit

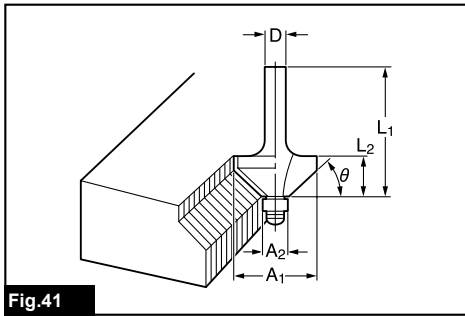

Fig.41

Unit:mm

D	A1	A2	L1	L2	θ
6	26	8	42	12	45°
1/4"					
6	20	8	41	11	60°

### Ball bearing beading bit

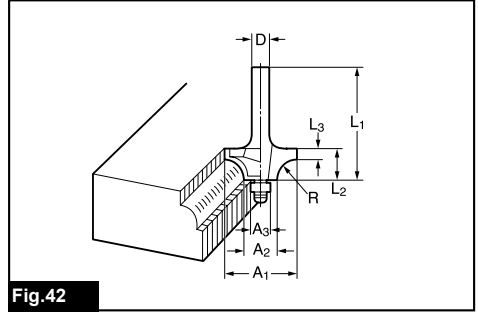

Fig.42

Unit:mm

D	A1	A2	A3	L1	L2	L3	R
6	20	12	8	40	10	5.5	4
6	26	12	8	42	12	4.5	7

### Ball bearing cove beading bit

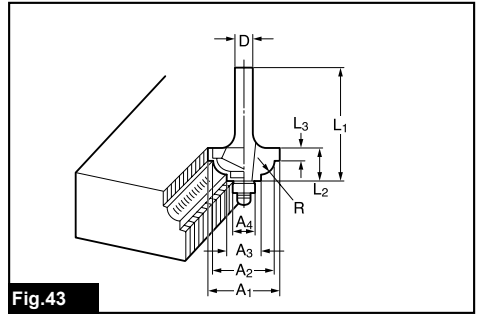
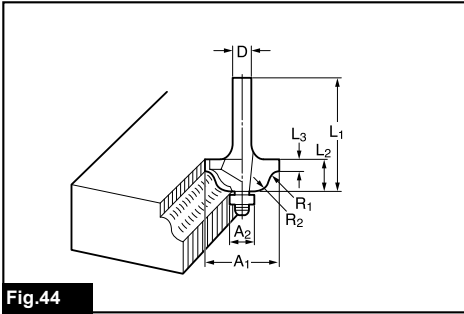

Fig.43

Unit:mm

D	A1	A2	A3	A4	L1	L2	L3	R
6	20	18	12	8	40	10	5.5	3
6	26	22	12	8	42	12	5	5

## Ball bearing roman ogee bit

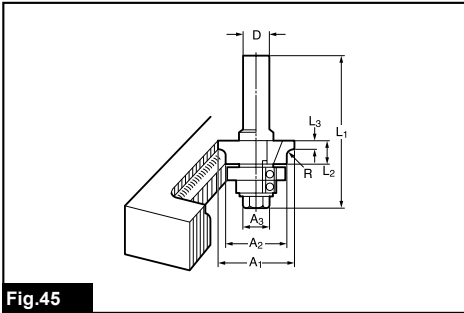

**Fig.44**

Unit:mm

D	A1	A2	L1	L2	L3	R1	R2
6	20	8	40	10	4.5	2.5	4.5
6	26	8	42	12	4.5	3	6

## Double ball bearing round corner bit



**Fig.45**

Unit:mm

D	A1	A2	A3	L1	L2	L3	R
12	35	27	19	70	11	3.5	3
1/2"							

**Makita** Jan-Baptist Vinkstraat 2, 3070, Belgium  
**Makita Corporation** Anjo, Aichi, Japan

[www.makita.com](http://www.makita.com)

885472-224 EN 20150928
------------------------------